



# MARINE KEEL COOLER OPTIMIZATION TOOL



Sponsored by Frank Ruggiero Cummins INC

Faculty Advisor: Steven W. Van Sciver, Ph.D.

## CONTEXT

### Introduction

Cummins Marine is in need of a better tool which would enable the Marine Application Engineers proper validation of the marine keel cooler cooling capacity for installation quality assurance. The current tool is limited providing only a 'Pass/Fail' output to the user and only analyzes steel keel coolers.

The team is faced with the creation of a new tool which will not only test the current keel cooler in a vessel, but also provide an option to design a keel cooler given information about the vessel installation. Such tool can be used before the vessel is made, after the engine has been installed, and during engine repowers.

### Problem Statement

*"The current Cummins Keel Cooler Tool provides no feedback on a particular design and is limited in its capability."*

### Goal Statement

*"Design a more versatile design tool which generates feedback and provides a more user friendly interface."*

### Objectives

- Create tool which successfully predicts the heat dissipation, efficiency and optimal operation temperatures for keel cooler
- Validate installed keel cooler systems in different vessel operating conditions
- Evaluate designs for different materials

## DESIGN

### Hardware Design

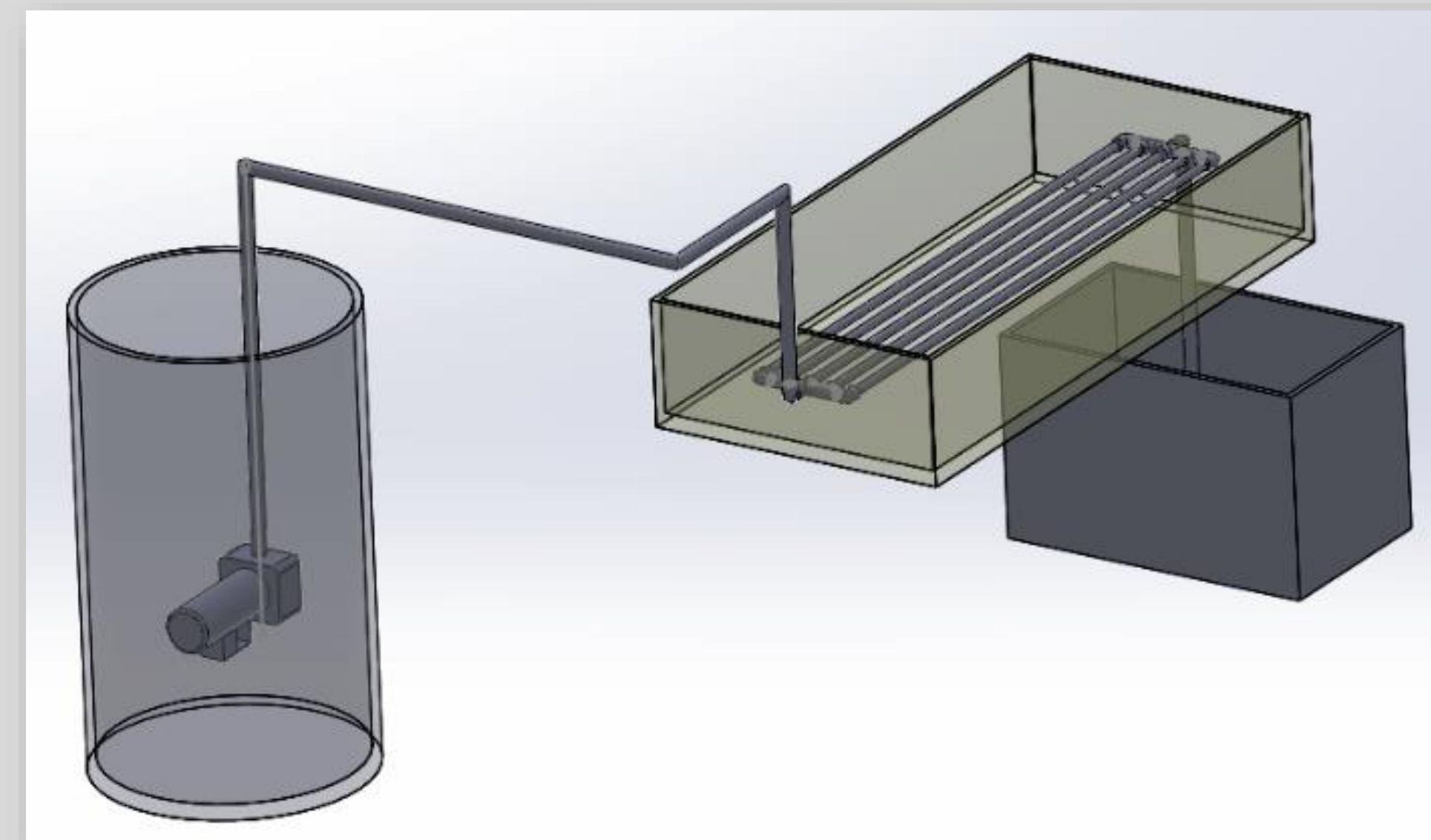

The testing apparatus will provide the team a means to validate the predictive engineering in the software. It will consist of a heated water reservoir, water pump, keel cooler, and water bath. It will simulate the worst case operating scenario for a vessel, wide open throttle for a vessel which is stationary.

### Software Design

The software will enable Marine Application Engineers and boat builders two modes, keel cooler design and/or validation.

#### Design:

User is asked to enter information about the vessel installation. The program will then output a keel cooler design complete with accurate sizing per material selection.

#### Validation:

User is asked to input information of a current installation to validate the cooling capacity of the current keel cooler in different operating conditions. If current design fails, user will be taken to the 'Design' mode.

## TESTING

The testing apparatus to validate the team's engineering intuition, shall be conducted using the following steps:

- 1) Heat water reservoir
- 2) Pump hot water through keel cooler apparatus
- 3) Record inlet and outlet temperatures of the keel cooler apparatus using thermocouples
- 4) Record bath temperature before, during, and after testing
- 5) Calculate thermal efficiency of keel cooler apparatus

The testing apparatus will test multiple flow paths versus one flow path. The same material will be used in both tests allowing the team to fully understand how flow paths change heat transfer.

## FUTURE WORK

- 1) Select and order hardware components
- 2) Assemble hardware components for testing
- 3) Test and verify our engineering intuition using hardware
- 4) Implement heat transfer equations into software
- 5) Send software to Cummins Marine South Carolina for testing and product feedback
- 6) Complete and modify user interface

## ACKNOWLEDGEMENTS

The team would like to acknowledge our advisor, Dr. Van Sciver for his insight and direction. We would also like to acknowledge Frank Ruggiero for the sponsorship of this project.